

LINEPRO 20090 | 20190 | 20290

Square shoulder milling
new generation



LINEPRO 20090

P M K N S

INSERT SIZE
06 XP...
0602...

XPET-LP

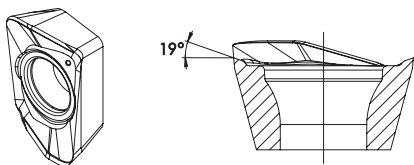

XPET-LN

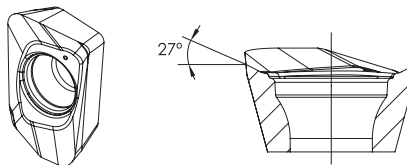

XPET-HF

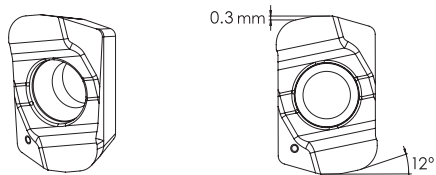

XPHW-MH

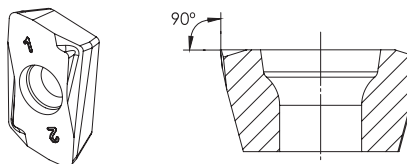

XPET-LP



XPET-HF



XPET-LN



XPHW-MH



LINEPRO 20190

INSERT SIZE
10 XP...
1003...

XPET-LP

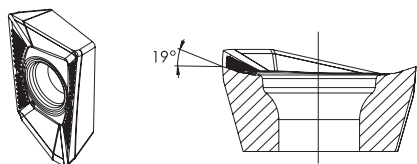

XPET-MP

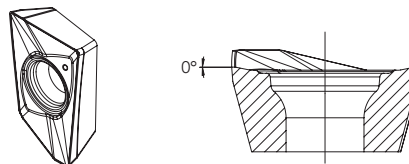

XPET-LN

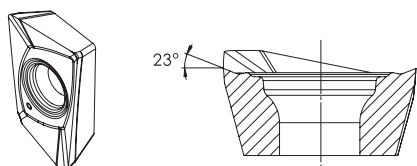

XPET-LS

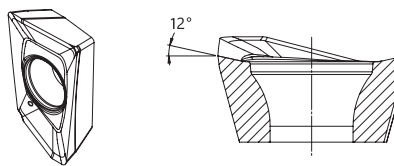

XPET-HF

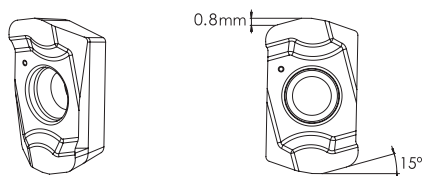

XPET-LP



XPET-MP



XPET-LS



XPET-LN



XPET-HF



XPHW-MH



XPHW-RZ1



XPHW-MH

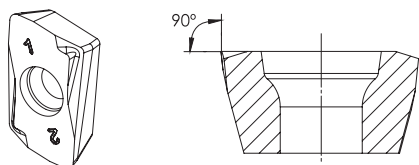

XPHW-Z1 | Z1W

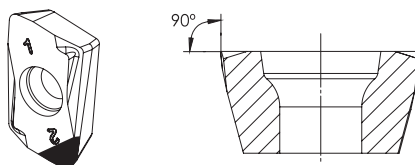

LINEPRO 20290

P M K N S

INSERT SIZE
17 XPET
1706...

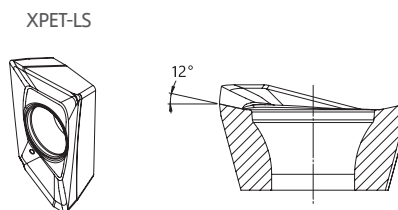
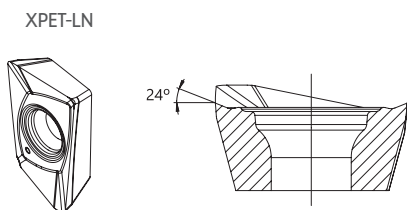
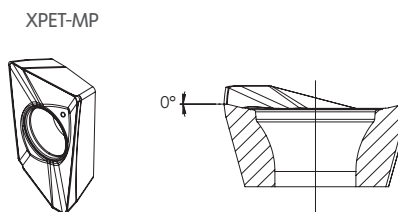
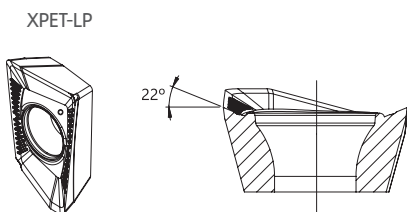

XPET-LP



XPET-MP



XPET-LS



XPET-LN



CHIP BREAKERS Quebra- aparas | Rompevirutas

Chip Breaker	Features Características Características
Geometry HF Hifeed machining	New chipbreaker HF for Hifeed machining in all materials.
Geometry LP Light machining	Positive top rake angle to promote a good chip flow and reduce power consumption on low alloy steels.
Geometry MP Light machining	Chip-breaker with a reinforced chamfer for general applications on steel and cast iron.
Geometry LS Light machining	Positive chip-breaker dedicated to stainless steel and HRSA.
Geometry LN Light machining	High positive chip-breaker, polished for applications of non ferrous materials (aluminum).
Geometry MH Light machining	First choice for Hard Materials in finishing operations.
Geometry RZ1 Light machining	PCD tip chip-breaker, for applications of non ferrous materials (aluminum).

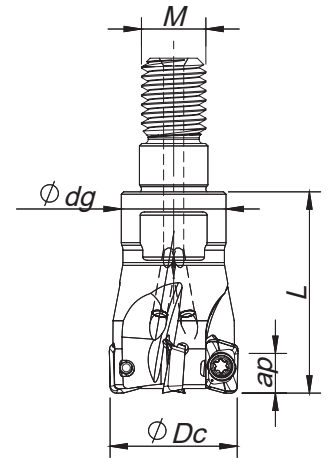

Threaded Coupling

$K_r=90^\circ$ | $\gamma_p=+4^\circ$

Order code Código	Reference Referência Referencia		Dimensions Dimensões Dimensiones (mm)				Kg	Ap max (mm)			Insert Pastilha Inserto	Stock
			ϕDc	ϕM	ϕdg	L		LP LN	HF	MH		
181120400	010R20090-02-04-M06020	2	10	M6	9,8	20	0,01	4,00	0,30	2,00	XP.. 0602...	
181112800	011R20090-02-04-M06020	2	11	M6	9,8	20	0,01	4,00	0,30	2,00	XP.. 0602...	
181120500	012R20090-03-04-M06020	3	12	M6	9,8	20	0,02	4,00	0,30	2,00	XP.. 0602...	
181112900	013R20090-03-04-M06020	3	13	M6	9,8	20	0,02	4,00	0,30	2,00	XP.. 0602...	
181087500	016R20090-04-04-M08025	4	16	M8	13,0	25	0,03	4,00	0,30	2,00	XP.. 0602...	
181113000	017R20090-04-04-M08025	4	17	M8	13,0	25	0,04	4,00	0,30	2,00	XP.. 0602...	
181087600	020R20090-05-04-M10030	5	20	M10	18,0	30	0,06	4,00	0,30	2,00	XP.. 0602...	
181087700	025R20090-07-04-M12030	7	25	M12	21,0	30	0,09	4,00	0,30	2,00	XP.. 0602...	
181087800	032R20090-08-04-M16035	8	32	M16	29,0	35	0,19	4,00	0,30	2,00	XP.. 0602...	

Stock item | Produto de stock | Itens de stock

Available under request | Disponível sobre consulta | Disponible bajo consulta

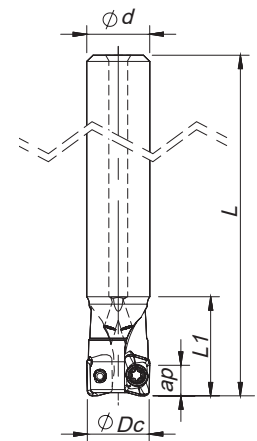

Cylindrical Shank

$K_r=90^\circ$ | $\gamma_p=+4^\circ$

Order code Código	Reference Referência Referencia		Dimensions Dimensões Dimensiones (mm)				Kg	Ap max (mm)			Insert Pastilha Inserto	Stock
			ϕDc	ϕM	ϕdg	L		LP LN	HF	MH		
181087100	010E20090-02-04-010055	2	10	10	55	16	0,03	4,00	0,30	2,00	XP.. 0602...	
181108300	010E20090-02-04-010100	2	10	10	100	25	0,03	4,00	0,30	2,00	XP.. 0602...	
181087200	012E20090-02-04-012080	2	12	12	80	17	0,06	4,00	0,30	2,00	XP.. 0602...	
181109900	012E20090-03-04-012120	3	12	12	120	30	0,06	4,00	0,30	2,00	XP.. 0602...	
181087300	016E20090-03-04-016090	3	16	16	90	20	0,12	4,00	0,30	2,00	XP.. 0602...	
181087400	016E20090-04-04-016090	4	16	16	90	20	0,11	4,00	0,30	2,00	XP.. 0602...	
181097100	017E20090-05-04-016090	5	17	16	90	35	0,11	4,00	0,30	2,00	XP.. 0602...	
181097200	021E20090-05-04-020090	5	21	20	90	35	0,13	4,00	0,30	2,00	XP.. 0602...	

Stock item | Produto de stock | Itens de stock

Available under request | Disponível sobre consulta | Disponible bajo consulta

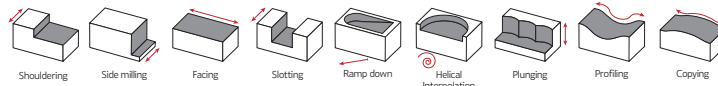

XP... 0602... Inserts | Pastilhas | Plaquetas



XPET-LP



XPET-LN

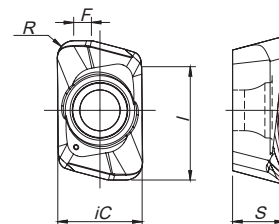

XPET-LP | LN

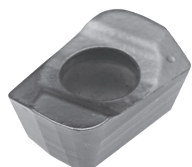

XPET-HF
(HiFeed geometry)

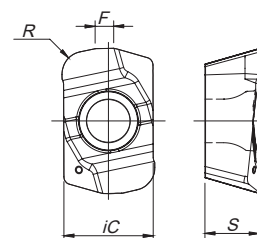

XPET-HF

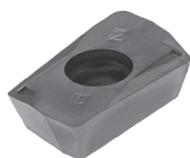

XPHW-MH
(finishing geometry)

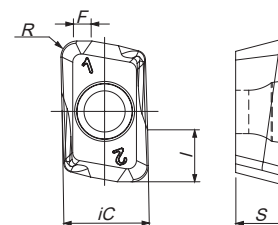

XPHW-MH

Geometry code	ISO Reference	P				M	K		N	S	H		Dimensions Dimensões Dimensiones (mm)				
		PVD				PVD	PVD		UNC	PVD	PVD						
		X4	X6	T1	P4	X9	T1	P4	10	X9	X4	X6					
1112520	XPET 060202 PDER-LP			○		○	○		○			3,90	2,40	5,10	0,20	1,00	
1112002	XPET 060204 PDER-LP			⊗	⊗	⊗	⊗		⊗			3,90	2,40	5,30	0,40	0,80	
1112003	XPET 060208 PDER-LP			⊗	⊗	⊗	⊗		⊗			3,90	2,40	5,30	0,80	0,60	
1112004	XPET 060216 PDER-LP			⊗	⊗		⊗	⊗				3,90	2,40	5,30	1,60	0,50	
1112579	XPET 060202 PDFR-LN								⊗			3,90	2,40	5,10	0,20	0,95	
1112580	XPET 060204 PDFR-LN								⊗			3,90	2,40	5,10	0,40	0,80	
1112581	XPET 060208 PDFR-LN								○			3,90	2,40	5,10	0,80	0,92	
1112716	XPET 060212 PDFR-LN								○			3,90	2,40	5,10	1,20	0,58	
1112049	XPET 060210 ZER-HF			⊗	⊗	⊗	⊗	⊗		⊗		3,90	2,40	-	1,00	0,80	
1112259	XPHW 060208 ZER-MH	⊗	⊗								⊗	⊗	3,90	2,40	2,40	0,80	0,70

⊗ First choice | Primeira opção | 1ª opción ⊗ Stock item | Produto de stock | Itens de stock ○ Available under request | Disponível sobre consulta | Disponible bajo consulta Insert order code = (1) Geometry Code + (2) Grade Code

SPARE PARTS Acessórios | Repuestos

Cutter ØDc	Insert Screw	Key (Torx)	Order separately	
			Key (Torx - Nm)	Torque Value
E20090 - 10	P0180300	XT06IP	DT0606IP	0,6
E20090 - 12-21	P0180400	XT06IP	DT0606IP	0,6
R20090 - 10	P0180300	XT06IP	DT0606IP	0,6
R20090 - 12-32	P0180400	XT06IP	DT0606IP	0,6

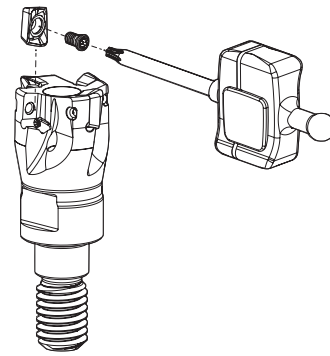

GRADES SELECTION GUIDE Guia para selecção de graus | Tabla para selección de calidades

ISO	PSM	Material	HB (Brinell)	Grades					
				← Wear Resistance			Toughness →		
				PH0910	PHH603	PHH910	PHP920	PHP930	PHH930
P	1	Unalloyed Steel	125-220	●	●	●	●	●	●
	2	Low-Alloyed Steel	220-280			✓	✓	✓	
	3	High-Alloyed Steel	280-380		✓	✓	✓	✓	
M	4	SS - Ferritic / Martensitic	200-330						✓
	5	SS - Austenitic	200-330						✓
	6	SS - Austenitic-ferritic (Duplex)	230-260						✓
K	7	Malleable Cast Iron	130-230				✓	✓	
	8	Grey Cast Iron	180-245				✓	✓	
	9	Nodular Cast iron	160-250				✓	✓	
N	10	Aluminium and Non Ferrous	30-130	✓					
S	11	Heat Resistant Super Alloys	200-320						✓
H	12	Hardened Steels	40-55 HRC		✓	✓			

Good Conditions
 Average Conditions
 Difficult Conditions

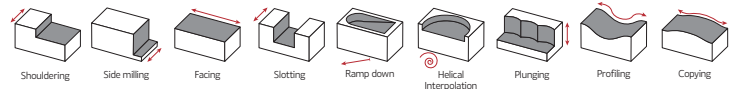

RECOMMENDED CUTTING CONDITIONS Condições de corte recomendadas | Condiciones de corte recomendables

ISO	PSM	Material	HB (Brinell)	Vc (m/min)					
				← Wear Resistance				Toughness →	
				PH0910	PHH603	PHH910	PHP920	PHP930	PHH930
P	1	Unalloyed Steel	125-220	-	-	-	180-250	160-230	-
	2	Low-Alloyed Steel	220-280	-	-	160-270	160-230	140-210	-
	3	High-Alloyed Steel	280-380	-	180-310	140-230	140-220	120-200	-
M	4	SS - Ferritic / Martensitic	200-330	-	-	-	-	-	140-210
	5	SS - Austenitic	200-330	-	-	-	-	-	120-170
	6	SS - Austenitic-ferritic (Duplex)	230-260	-	-	-	-	-	100-150
K	7	Malleable Cast Iron	130-230	-	-	-	160-270	150-250	-
	8	Grey Cast Iron	180-245	-	-	-	140-250	140-230	-
	9	Nodular Cast iron	160-250	-	-	-	120-210	100-200	-
N	10	Aluminium and Non Ferrous	30-130	100-2000	-	-	-	-	-
S	11	Heat Resistant Super Alloys	200-320	-	-	-	-	-	30-110
H	12	Hardened Steels	40-55 HRC	-	70-270	70-260	-	-	-

ISO	PSM	Material	HB (Brinell)	Feed fz (mm/t)			
				XPET 06...LP	XPET 06...LN	XPET 06...HF	XPHW 06...MH
P	1	Unalloyed Steel	125-220	0,05-0,07	-	0,40-0,80	-
	2	Low-Alloyed Steel	220-280	0,05-0,07	-	0,40-0,80	0,05-0,12
	3	High-Alloyed Steel	280-380	0,05-0,07	-	0,40-0,60	0,05-0,12
M	4	SS - Ferritic / Martensitic	200-330	0,05-0,07	-	0,40-0,80	-
	5	SS - Austenitic	200-330	0,05-0,07	-	0,40-0,60	-
	6	SS - Austenitic-ferritic (Duplex)	230-260	0,05-0,07	-	0,40-0,60	-
K	7	Malleable Cast Iron	130-230	0,05-0,07	-	0,40-0,80	-
	8	Grey Cast Iron	180-245	0,05-0,07	-	0,40-0,80	-
	9	Nodular Cast iron	160-250	0,05-0,07	-	0,40-0,80	-
N	10	Aluminium and Non Ferrous	30-130	-	0,05-0,07	-	-
S	11	Heat Resistant Super Alloys	200-320	0,05-0,07	-	0,40-0,60	-
H	12	Hardened Steels	40-55 HRC	-	-	-	0,03-0,10

(Note 1) Cutting conditions $a_e/D_c=70\%$.

(Note 2)

Operation	a_e	Vc & fz	a_p (mm)
Slotting	100%	<20%	1,0-3,0
Shouldering	<50%	>8%	1,0-4,0
	≤25%	>12%	1,0-4,0

(Note 3) PH5... and PH8... can be used wet or dry. PH7... use only air.

(Note 4) It's possible to occur vibrations in certain cases. Please reduce depth of cut and / or reduce cutting conditions in following cases:

- When using long shank;
- When using long tool overhang with arbor type;
- When application has poor clamping rigidity or when using a low rigidity machine.

CHIP-BREAKER SELECTION GUIDE Guia para aplicações do quebra- aparas | Guía para aplicación del rompevirutas

ISO	PSM	Material	HB (Brinell)	Chip-Breaker Application	
				1st choice	Difficult Operations
P	1	Unalloyed Steel	125-220	XPET 06... LP/HF	-
	2	Low-Alloyed Steel	220-280	XPET 06... LP/HF	XPHW 06... MH
	3	High-Alloyed Steel	280-380	XPET 06... LP/HF	XPHW 06... MH
M	4	SS - Ferritic / Martensitic	200-330	XPET 06... LP/HF	-
	5	SS - Austenitic	200-330	XPET 06... LP/HF	-
	6	SS - Austenitic-ferritic (Duplex)	230-260	XPET 06... LP/HF	-
K	7	Malleable Cast Iron	130-230	XPET 06... LP/HF	-
	8	Grey Cast Iron	180-245	XPET 06... LP/HF	-
	9	Nodular Cast iron	160-250	XPET 06... LP/HF	-
N	10	Aluminium and Non Ferrous	30-130	XPET 06... LN	-
S	11	Heat Resistant Super Alloys	200-320	XPET 06... LP/HF	-
H	12	Hardened Steels	40-55 HRC	XPHW 06... MH	-

PROGRAMMING DATA Dados para programação | Datos para la programación

Insert	Programming Data		
	Rp	X	b
XPET 06 HF	1,1	0,84	2,3

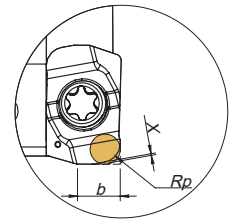

PLUNGING Mergulho | Plunge

L ≤ 3Dc	L > 3Dc	S max.
fz (mm/t)		
0,04-0,07	0,03-0,05	$S_{max} = \sqrt{D_c \cdot DR - DR^2}$

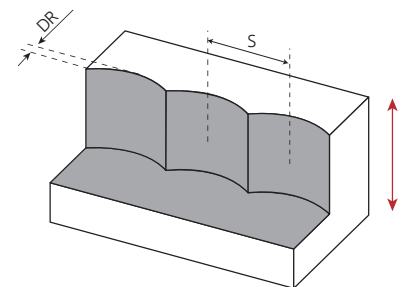

S max and DR corresponding cutting diameter Dc (mm)								
DR (mm)	Dc (mm)							
	10	12	16	17	20	21	25	32
0,5	2,2	2,4	2,8	2,9	3,1	3,2	3,5	4,0
1	3,0	3,3	3,9	4,0	4,4	4,5	4,9	5,6
2*	4,0	4,5	5,3	5,5	6,0	6,2	6,8	7,7

* only for radius above 1,6mm

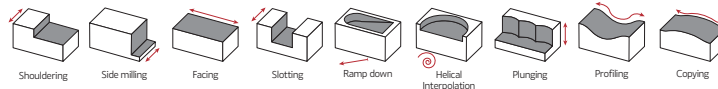

RAMPING AND HELICAL INTERPOLATION

Descida em rampa e interpolação helicoidal | Bajada en rampa e interpolación circular

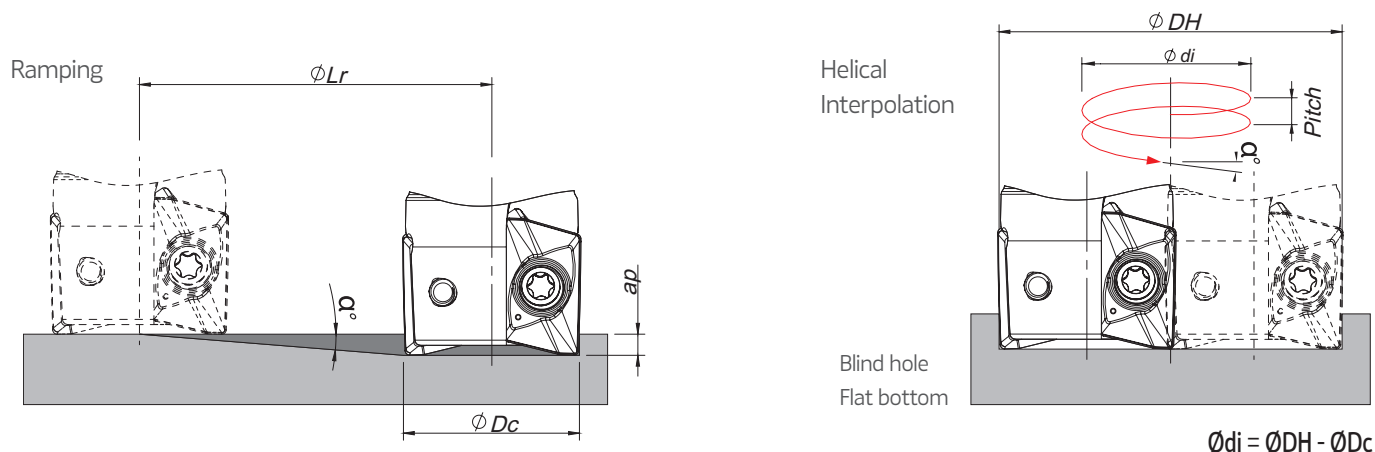

ϕD_c	Ramping			Helical Interpolation		
				Diameter for Blind Hole, Flat Bottom Face (1)		Max Pitch/Rev.
	Max Ramp α°	Max a_p	Min L_r	ϕDH_{min}	ϕDH_{max}	
10	5,5	4,0	41,5	17,2	-	2,2
				-	18,4	2,5
12	4,0	4,0	57,2	21,2	-	2,0
				-	22,4	2,3
16	2,5	4,0	91,6	29,2	-	1,8
				-	30,4	2,0
17	2,2	4,0	104,1	31,2	-	1,7
				-	32,4	1,9
20	1,9	4,0	120,6	37,2	-	1,8
				-	38,4	1,9
21	1,6	4,0	143,2	39,2	-	1,6
				-	40,4	1,7
25	1,3	4,0	171,0	47,2	-	1,6
				-	48,4	1,7
32	1,0	4,0	229,2	61,2	-	1,6
				-	62,4	1,7

(1) using LP insert with radius 0,8 mm

Note: During helical interpolation do not exceed maximum pitch

When using HF insert or other different insert radius to calculate the ϕDH_{min} and ϕDH_{max} use the equation below:

- Minimum Diameter: $\phi DH_{min} = 2 \times (\phi D_c - (R \text{ corner radius} + F \text{ width of edge wiper}))$

- Maximum Diameter: $\phi DH_{max} = 2 \times (\phi D_c - R \text{ corner radius})$

(On HF insert the corner radius should be corner radius programming)

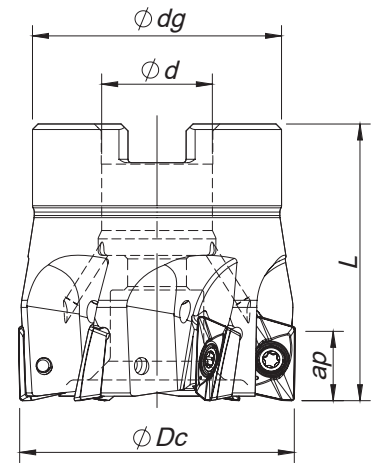
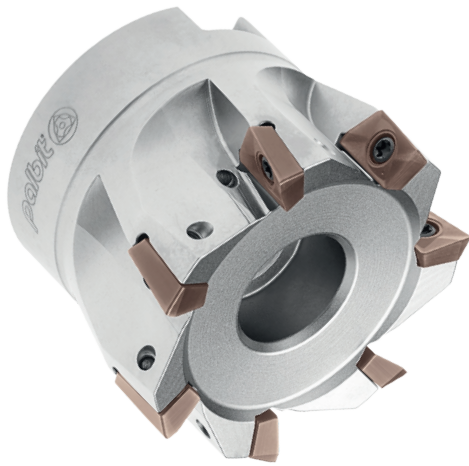

Arbor Mounting

$K_r=90^\circ$ | $\gamma_p=+8^\circ$

Order code Código	Reference Referência Referencia		Dimensions Dimensões Dimensiones (mm)				Kg	Arbor Type	Ap max (mm)				Insert Pastilha Inserto	Stock
			ϕDc	ϕd	ϕdg	L			LP/MP/LN	LS	HF	MH		
181088600	040A20190-06-08-016040		40	16	36	40	0,22	A	10,0	10,0	0,80	3,00	XP... 1003...	
181088700	050A20190-07-08-022040		50	22	42	40	0,31	A	10,0	10,0	0,80	3,00	XP... 1003...	
181088800	063A20190-08-08-022040		63	22	52	40	0,43	A	10,0	10,0	0,80	3,00	XP... 1003...	
181201900	040A20190-06-08-016040-B*		40	16	36	40	0,22	A	-	10,0	-	3,00	XP... 1003...	
181202100	050A20190-07-08-022040-B*		50	22	42	40	0,31	A	-	10,0	-	3,00	XP... 1003...	
181202300	060A20190-08-08-022040-B*		60	22	52	40	0,48	A	-	10,0	-	3,00	XP... 1003...	
181202200	063A20190-08-08-022040-B*		63	22	52	40	0,43	A	-	10,0	-	3,00	XP... 1003...	

Stock item | Produto de stock | Itens de stock

Available under request | Disponível sobre consulta | Disponible bajo consulta

Note: Type -B* cutters can only assemble inserts with a radius between 2,0 and 4,0.

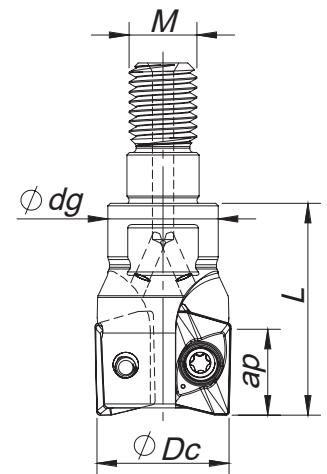

Threaded Coupling

$K_r=90^\circ$ | $\gamma_p=+5^\circ \sim +6^\circ$

Order code Código	Reference Referência Referencia		Dimensions Dimensões Dimensiones (mm)				Kg	Ap max (mm)				Insert Pastilha Inserto	Stock
			ϕDc	ϕM	ϕdg	L		LP/MP/LN	LS	HF	MH		
181088200	016R20190-02-05-M08025		16	M8	14	25	0,03	10,0	10,0	0,80	3,00	XP... 1003...	
181088300	020R20190-03-05-M10030		20	M10	18	30	0,06	10,0	10,0	0,80	3,00	XP... 1003...	
181088400	025R20190-04-05-M12035		25	M12	21	35	0,12	10,0	10,0	0,80	3,00	XP... 1003...	
181088500	032R20190-05-06-M16035		32	M16	29	35	0,15	10,0	10,0	0,80	3,00	XP... 1003...	
181149100	040R20190-06-08-M16043		40	M16	29	43	0,25	10,0	10,0	0,80	3,00	XP... 1003...	
181200100	016R20190-02-05-M08025-B*		16	M8	14	25	0,03	-	10,0	-	3,00	XP... 1003...	
181200700	020R20190-03-05-M10030-B*		20	M10	18	30	0,06	-	10,0	-	3,00	XP... 1003...	
181201300	025R20190-04-05-M12035-B*		25	M12	21	35	0,12	-	10,0	-	3,00	XP... 1003...	
181201700	032R20190-05-06-M16035-B*		32	M16	29	35	0,15	-	10,0	-	3,00	XP... 1003...	
181202000	040R20190-06-08-M16043-B*		40	M16	29	43	0,25	-	10,0	-	3,00	XP... 1003...	

Stock item | Produto de stock | Itens de stock

Available under request | Disponível sobre consulta | Disponible bajo consulta

Note: Type -B* cutters can only assemble inserts with a radius between 2,0 and 4,0.

LINEPRO 20190
XPET 10 | XPHW 10

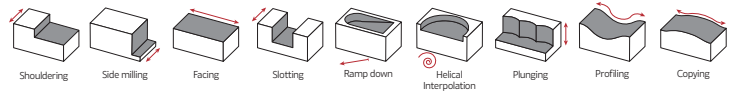

Weldon Shank

$K_r=90^\circ$ | $\gamma_p=+5^\circ\sim 8^\circ$

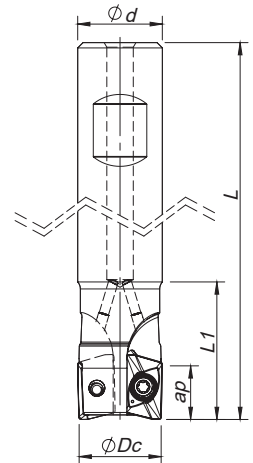

Order code Código	Reference Referência Referencia		Dimensions Dimensões Dimensiones (mm)				Kg	Ap max (mm)				Insert Pastilha Inserto	Stock
			ØDc	Ød	L	L1		LP/MP/LN	LS	HF	MH		
181087900	016W20190-02-05-016085	2	16	16	85	32	0,10	10,0	10,0	0,80	3,00	XP... 1003...	
181100600	016W20190-02-05-016150	2	16	16	150	70	0,13	10,0	10,0	0,80	3,00	XP... 1003...	
181108600	017W20190-02-05-016150	2	17	16	150	36	0,14	10,0	10,0	0,80	3,00	XP... 1003...	
181088000	020W20190-03-05-020090	3	20	20	90	28	0,21	10,0	10,0	0,80	3,00	XP... 1003...	
181100700	020W20190-03-05-020150	3	20	20	150	70	0,26	10,0	10,0	0,80	3,00	XP... 1003...	
181108700	022W20190-03-05-020150	3	22	20	150	70	0,30	10,0	10,0	0,80	3,00	XP... 1003...	
181088100	025W20190-04-05-025095	4	25	25	95	30	0,33	10,0	10,0	0,80	3,00	XP... 1003...	
181100800	025W20190-04-05-025150	4	25	25	150	80	0,36	10,0	10,0	0,80	3,00	XP... 1003...	
181108800	027W20190-04-05-025150	4	27	25	150	80	0,38	10,0	10,0	0,80	3,00	XP... 1003...	
181085400	032W20190-04-08-032110	4	32	32	110	50	0,55	10,0	10,0	0,80	3,00	XP... 1003...	
181200200	016W20190-02-05-016085-B*	2	16	16	85	32	0,10	-	10,0	-	3,00	XP... 1003...	
181200300	016W20190-02-05-016150-B*	2	16	16	150	70	0,13	-	10,0	-	3,00	XP... 1003...	
181200400	017W20190-02-05-016150-B*	2	17	16	150	36	0,14	-	10,0	-	3,00	XP... 1003...	
181200800	020W20190-03-05-020090-B*	3	20	20	90	28	0,21	-	10,0	-	3,00	XP... 1003...	
181200900	020W20190-03-05-020150-B*	3	20	20	150	70	0,26	-	10,0	-	3,00	XP... 1003...	
181201000	022W20190-03-05-020150-B*	3	22	20	150	70	0,30	-	10,0	-	3,00	XP... 1003...	
181201400	025W20190-04-05-025095-B*	4	25	25	95	30	0,33	-	10,0	-	3,00	XP... 1003...	
181201500	025W20190-04-05-025150-B*	4	25	25	150	80	0,36	-	10,0	-	3,00	XP... 1003...	
181201600	027W20190-04-05-025150-B*	4	27	25	150	80	0,38	-	10,0	-	3,00	XP... 1003...	
181201800	032W20190-04-08-032110-B*	4	32	32	110	50	0,55	-	10,0	-	3,00	XP... 1003...	

Stock item | Produto de stock | Itens de stock

Available under request | Disponível sobre consulta | Disponible bajo consulta

Note: Type -B* cutters can only assemble inserts with a radius between 2,0 and 4,0.

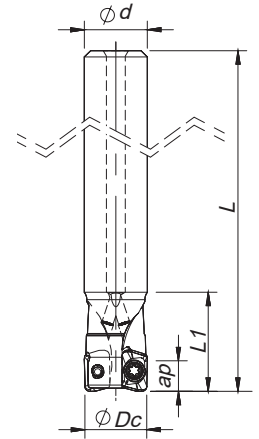

Cylindrical Shank

$K_r=90^\circ$ | $\gamma_p=+4^\circ$

Order code Código	Reference Referência Referencia		Dimensions Dimensões Dimensiones (mm)				Kg	Ap max (mm)				Insert Pastilha Inserto	Stock
			ϕDc	ϕd	L	L1		LP/MP/LN	LS	HF	MH		
181171700	016E20190-02-05-016085	2	16	16	85	32	0,10	10,0	10,0	0,80	3,00	XP... 1003...	
181173000	016E20190-02-05-016150	2	16	16	150	70	0,13	10,0	10,0	0,80	3,00	XP... 1003...	
181171600	020E20190-03-05-020090	3	20	20	90	28	0,14	10,0	10,0	0,80	3,00	XP... 1003...	
181171800	020E20190-03-05-020150	3	20	20	150	70	0,21	10,0	10,0	0,80	3,00	XP... 1003...	
181171400	025E20190-04-05-025095	4	25	25	95	30	0,26	10,0	10,0	0,80	3,00	XP... 1003...	
181172900	025E20190-04-05-025150	4	25	25	150	80	0,30	10,0	10,0	0,80	3,00	XP... 1003...	
181199900	016E20190-02-05-016085-B*	2	16	16	85	32	0,10	-	10,0	-	3,00	XP... 1003...	
181200000	016E20190-02-05-016150-B*	2	16	16	150	70	0,13	-	10,0	-	3,00	XP... 1003...	
181200500	020E20190-03-05-020090-B*	3	20	20	90	28	0,14	-	10,0	-	3,00	XP... 1003...	
181200600	020E20190-03-05-020150-B*	3	20	20	150	70	0,21	-	10,0	-	3,00	XP... 1003...	
181201100	025E20190-04-05-025095-B*	4	25	25	95	30	0,26	-	10,0	-	3,00	XP... 1003...	
181201200	025E20190-04-05-025150-B*	4	25	25	150	80	0,30	-	10,0	-	3,00	XP... 1003...	

Stock item | Produto de stock | Itens de stock

Available under request | Disponível sobre consulta | Disponible bajo consulta

Note: Type -B* cutters can only assemble inserts with a radius between 2,0 and 4,0.

SPARE PARTS Acessórios | Repuestos

Cutter ϕDc	Insert Screw 	Key (Torx) 	Order separately	
			Key (Torx - Nm) 	Torque Value
A20190 - 40-63	P0250704	XT08	DT0812	1,2
R20190 - 16	P0250503	XT08	DT0812	1,2
R20190 - 20-40	P0250704	XT08	DT0812	1,2
W20190 - 16-17	P0250503	XT08	DT0812	1,2
W20190 - 20-32	P0250704	XT08	DT0812	1,2
E20190 - 16	P0250503	XT08	DT0812	1,2
E20190 - 20-25	P0250704	XT08	DT0812	1,2

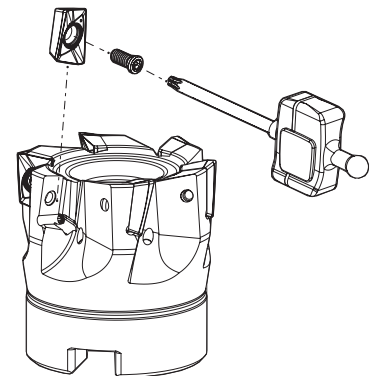

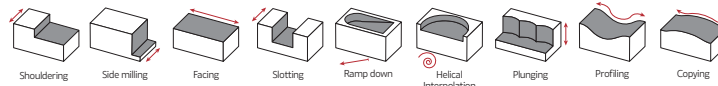

TOOLHOLDER TYPES: A VS. B



Toolholders are designed to accommodate inserts with various radius. On the LinePro 20190 toolholders, there are two types that can be distinguished by their specific features.

Toolholder Types: A vs. B

- > **Type A Toolholders**, denoted by the "-A" reference, are tailored for inserts with radius of 0.4, 0.8, 1.2, and 1.6 mm. It's important to note that the "-A" reference is hidden by default. These toolholders are characterized by a more streamlined and less pronounced radius support, making them suitable for smaller insert radius.
- > **Type B Toolholders**, denoted by the "-B" reference, are intended for inserts with larger radius of 2.0, 3.2, and 4.0 mm. They stand out with a pronounced radius support, which allows for a more secure fit and excellent performance when used with inserts of these sizes.

When distinguishing between the two, look for the degree of rounding in the supports; Type B toolholders, indicated by the "-B" reference, feature more substantial radius supports, making them easily identifiable.

XPET 1003... Inserts | Pastilhas | Plaquetas

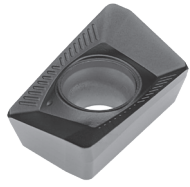

XPET-LP

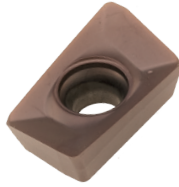

XPET-LS

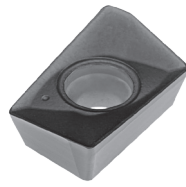

XPET-MP



XPET-LN

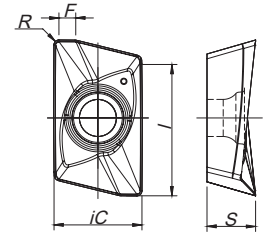

XPET-LP | LS | MP | LN



XPET-HF
(HiFeed geometry)

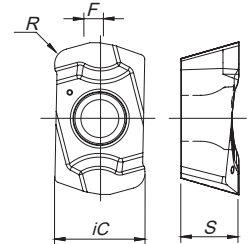

XPET-HF

Geometry code	ISO Reference	P					M	K					N		S	H		Dimensions Dimensões Dimensiones (mm)				
		CVD		PVD			PVD	CVD		PVD			UNC	PCD	PVD	PVD		iC	S	I	R	F
		T9	G1	X5	T1	P4	X9	L5	L9	X5	T1	P4	10	D6	X9	X4	X6					
1113132	XPET 100302 PDER-LP						⊗								⊗			6,95	3,96	10,50	0,20	1,50
1111980	XPET 100304 PDER-LP				⊗	⊗	⊗								⊗	⊗		6,95	3,96	10,50	0,40	1,30
1111981	XPET 100308 PDER-LP	⊗			⊗	⊗	⊗								⊗	⊗		6,95	3,96	10,50	0,80	1,40
1112022	XPET 100316 PDER-LP				⊗	⊗	⊗								⊗			6,95	3,96	10,50	1,60	0,80
1113365	XPET 100304 PDER-LS				⊗		⊗								⊗			6,95	3,96	10,5	0,40	1,90
1112197	XPET 100308 PDER-LS				⊗		⊗								⊗			6,95	3,96	10,5	0,80	1,50
1113358	XPET 100312 PDER-LS				⊗		⊗								⊗			6,95	3,96	10,5	1,20	1,00
1113366	XPET 100316 PDER-LS				⊗		⊗								⊗			6,95	3,96	10,5	1,60	0,80
1113359	XPET 100320 PDER-LS				⊗		⊗								⊗			6,95	3,96	10,5	2,00	1,60
1113360	XPET 100332 PDER-LS				⊗		⊗								⊗			6,95	3,96	10,5	3,20	0,50
1113394	XPET 100340 PDER-LS				○		○								○			6,95	3,96	10,5	4,00	0,20
1111982	XPET 100304 PDSR-MP		⊗	○	⊗	⊗		⊗	⊗	○	⊗	⊗						6,95	3,96	10,50	0,40	1,10
1111983	XPET 100308 PDSR-MP	⊗		⊗	⊗	⊗		⊗	⊗	⊗	⊗	⊗						6,95	3,96	10,50	0,80	1,35
1111984	XPET 100304 PDFR-LN													⊗				6,95	3,96	10,50	0,40	0,75
1112906	XPET 100308 PDFR-LN													⊗				6,95	3,96	10,50	0,80	1,05
1111985	XPET 100312 PDFR-LN													⊗				6,95	3,96	10,50	1,20	0,75
1112376	XPET 100312 ZDR-HF			⊗	⊗	⊗	⊗			⊗	⊗	⊗			⊗			6,95	3,96	-	1,20	1,50

⊗ First choice | Primeira opção | 1ª opción ⊗ Stock item | Produto de stock | Itens de stock ○ Available under request | Disponível sobre consulta | Disponible bajo consulta Insert order code = (1) Geometry Code + (2) Grade Code

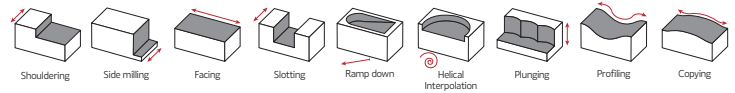

XPHW 1003... Inserts | Pastilhas | Plaquetas

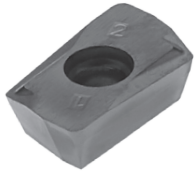

XPHW-MH
(finishing geometry)

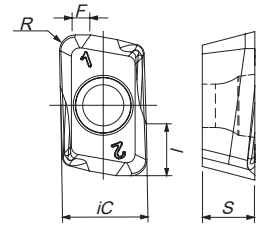

XPHW-MH

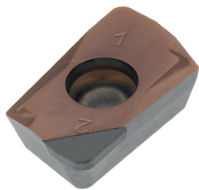

XPHW-R Z1

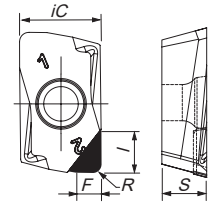

XPHW-R Z1

		P					M	K					N		S	H		Dimensions Dimensões Dimensiones (mm)				
		CVD		PVD			PVD	CVD		PVD			UNC	PCD	PVD	PVD						
		T9	G1	X5	T1	P4	X9	L5	L9	X5	T1	P4	10	D6	X9	X4	X6					
(1) Geometry code	(2) Grade code	PHS740	PH7910	PHP910	PHP920	PHP930	PHH930	PH5705	PH5740	PHP910	PHP920	PHP930	PH0910	PDP410	PHH930	PHH603	PHH910	iC	S	I	R	F
1112500	XPHW 100308 ZER-MH															Ⓢ	Ⓢ	6,95	3,60	3,00	0,80	1,30
1112736	XPHW 100310 ZER-MH															Ⓢ		6,95	3,60	3,00	1,00	0,35
1112735	XPHW 100320 ZER-MH															Ⓢ		6,95	3,60	3,00	1,20	1,10
1112556	XPHW 100308 R Z1													Ⓢ				6,95	3,60	3,80	0,80	2,30

Ⓢ First choice | Primeira opção | 1ª opción
Ⓢ Stock item | Produto de stock | Itens de stock
○ Available under request | Disponível sobre consulta | Disponible bajo consulta
Insert order code = (1) Geometry Code + (2) Grade Code

RECOMMENDED CUTTING CONDITIONS Condições de corte recomendadas | Condiciones de corte recomendables

ISO	PSM	Material	HB (Brinell)	Vc (m/min)									PCD
				← Wear Resistance						Toughness →			
				PH0910	PH5705	PHH603	PHP910	PHP920	PHP930	PHH930	PH5740	PHS740	
P	1	Unalloyed Steel	125-220	-	-	-	180-250	180-250	160-230	-	-	140-220	-
	2	Low-Alloyed Steel	220-280	-	-	-	160-240	160-230	140-210	-	-	120-200	-
	3	High-Alloyed Steel	280-380	-	-	180-310	140-230	140-220	120-200	-	-	100-190	-
M	4	SS - Ferritic / Martensitic	200-330	-	-	-	-	-	-	140-210	-	-	-
	5	SS - Austenitic	200-330	-	-	-	-	-	-	120-170	-	-	-
	6	SS - Austenitic-ferritic (Duplex)	230-260	-	-	-	-	-	-	100-150	-	-	-
K	7	Malleable Cast Iron	130-230	-	160-290	-	180-300	160-270	150-250	-	160-260	-	-
	8	Grey Cast Iron	180-245	-	170-320	-	160-250	140-250	140-230	-	140-240	-	-
	9	Nodular Cast iron	160-250	-	140-200	-	150-210	120-210	100-200	-	120-200	-	-
N	10	Aluminium and Non Ferrous	30-130	100-2000	-	-	-	-	-	-	-	-	800-3000
S	11	Heat Resistant Super Alloys	200-320	-	-	-	-	-	-	30-110	-	-	-
H	12	Hardened Steels	40-55 HRC	-	-	70-270	-	-	-	-	-	-	-

ISO	PSM	Material	HB (Brinell)	Feed fz (mm/t)						
				XPET 10... LP	XPET 10... LS	XPET 10... MP	XPET 10... LN	XPET 10... HF	XPHW 10... R Z1	XPHW 10... MH
P	1	Unalloyed Steel	125-220	0,08-0,20	-	0,10-0,25	-	0,40-0,80	-	0,10-0,25
	2	Low-Alloyed Steel	220-280	0,08-0,20	-	0,10-0,20	-	0,40-0,80	-	0,10-0,25
	3	High-Alloyed Steel	280-380	0,08-0,15	-	0,10-0,20	-	0,40-0,60	-	0,10-0,25
M	4	SS - Ferritic / Martensitic	200-330	0,08-0,20	0,08-0,20	0,10-0,20	-	0,40-0,70	-	-
	5	SS - Austenitic	200-330	0,08-0,20	0,08-0,20	0,10-0,20	-	0,40-0,70	-	-
	6	SS - Austenitic-ferritic (Duplex)	230-260	0,08-0,15	0,08-0,15	0,10-0,20	-	0,40-0,60	-	-
K	7	Malleable Cast Iron	130-230	0,08-0,20	-	0,10-0,25	-	0,50-0,80	-	-
	8	Grey Cast Iron	180-245	0,08-0,20	-	0,10-0,25	-	0,50-0,80	-	-
	9	Nodular Cast iron	160-250	0,08-0,20	-	0,10-0,20	-	0,50-0,60	-	-
N	10	Aluminium and Non Ferrous	30-130	-	-	-	0,07-0,25	-	0,10-0,25	-
S	11	Heat Resistant Super Alloys	200-320	0,05-0,07	0,05-0,07	-	-	0,40-0,60	-	-
H	12	Hardened Steels	40-55 HRC	-	-	-	-	-	-	0,08-0,15

(Note 1) Cutting conditions $a_e/D_c=70\%$.

(Note 2)

Operation	a_e	Vc & fz	a_p (mm)
Slotting	100%	<20%	2,0-4,0
Shouldering	<50%	>8%	3,0-6,0
	≤25%	>12%	7,0-9,0

(Note 3) PH5... and PHS... can be used wet or dry. PH7... use only air.

(Note 4) It's possible to occur vibrations in certain cases. Please reduce depth of cut and / or reduce cutting conditions in following cases:

- When using long shank;
- When using long tool overhang with arbor type;
- When application has poor clamping rigidity or when using a low rigidity machine.

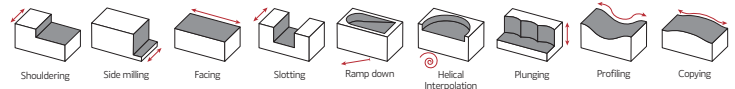

CHIP-BREAKER SELECTION GUIDE Guia para aplicações do quebra-apanas | Guía para aplicación del rompevirutas

ISO	PSM	Material	HB (Brinell)	Chip-Breaker Application	
				1st choice	Difficult Operations
P	1	Unalloyed Steel	125-220	XPET 10 ... LP/HF	XPET 10 ... MP
	2	Low-Alloyed Steel	220-280	XPET 10 ... LP/HF	XPET 10 ... MP
	3	High-Alloyed Steel	280-380	XPET 10 ... MP/HF	-
M	4	SS - Ferritic / Martensitic	200-330	XPET 10 ... LS	XPET 10 ... LP/HF
	5	SS - Austenitic	200-330	XPET 10 ... LS	XPET 10 ... LP/HF
	6	SS - Austenitic-ferritic (Duplex)	230-260	XPET 10 ... LS	XPET 10 ... LP/HF
K	7	Malleable Cast Iron	130-230	XPET 10 ... LP/HF	XPET 10 ... MP
	8	Grey Cast Iron	180-245	XPET 10 ... MP/HF	-
	9	Nodular Cast iron	160-250	XPET 10 ... MP/HF	-
N	10	Aluminium and Non Ferrous	30-130	XPET 10 ... LN/R Z1	-
S	11	Heat Resistant Super Alloys	200-320	XPET 10 ... LS	XPET 10 ... LP/HF
H	12	Hardened Steels	40-55 HRC	XPHW 10 ... MH	-

GRADES SELECTION GUIDE Guia para selecção de graus | Tabla para selección de calidades

ISO	PSM	Material	HB (Brinell)	Grades							PCD	
				← Wear Resistance				Toughness →				
				PH0910	PH5705	PHH603	PHP910	PHP920	PHP930	PHH930		PH5740
P	1	Unalloyed Steel	125-220	●	●	●	●	●	●	●	●	●
	2	Low-Alloyed Steel	220-280				●	●	●			●
	3	High-Alloyed Steel	280-380			●	●	●	●			●
M	4	SS - Ferritic / Martensitic	200-330							●		
	5	SS - Austenitic	200-330							●		
	6	SS - Austenitic-ferritic (Duplex)	230-260							●		
K	7	Malleable Cast Iron	130-230		●		●	●	●		●	
	8	Grey Cast Iron	180-245		●		●	●	●		●	
	9	Nodular Cast iron	160-250		●		●	●	●		●	
N	10	Aluminium and Non Ferrous	30-130	●								●
S	11	Heat Resistant Super Alloys	200-320							●		
H	12	Hardened Steels	40-55 HRC			●						

Good Conditions
 Average Conditions
 Difficult Conditions

PROGRAMMING DATA Dados para programação | Datos para la programación

Insert	Programming Data		
	Rp	X	b
XPET 10 HF	1,6	0,33	3,45

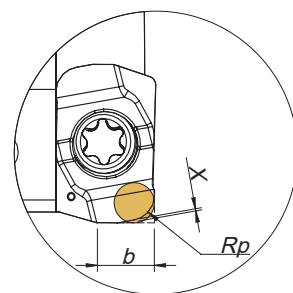

PLUNGING Mergulho | Plunge

L ≤ 3Dc	L > 3Dc	S max.
fz (mm/t)		
0,08-0,20	0,06-0,15	$S_{max} = \sqrt{D_c \cdot DR - DR^2}$

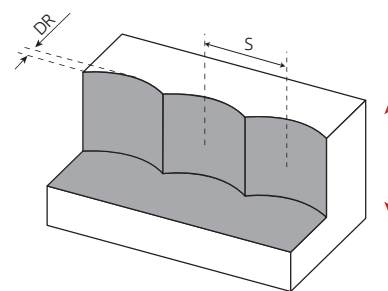

S max and DR corresponding cutting diameter Dc (mm)										
DR (mm)	Dc (mm)									
	16	17	20	22	25	27	32	40	50	63
1	3,9	4,0	4,4	4,6	4,9	5,1	5,6	6,2	7,0	7,9
2	5,3	5,3	6,0	8,8	6,8	10,2	7,7	8,7	9,8	17,0
3*	6,2	6,2	7,1	9,3	8,1	10,8	9,3	10,5	11,9	18,3
4**	6,9	6,9	8,0	9,5	9,2	11,2	10,6	12,0	13,6	19,2

* only for radius above 2,0mm

** only for radius 4,0mm

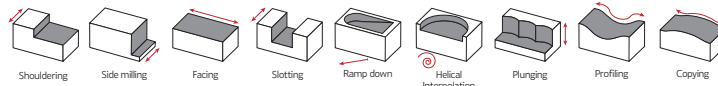

RAMPING AND HELICAL INTERPOLATION

Descida em rampa e interpolação helicoidal | Bajada en rampa e interpolación circular

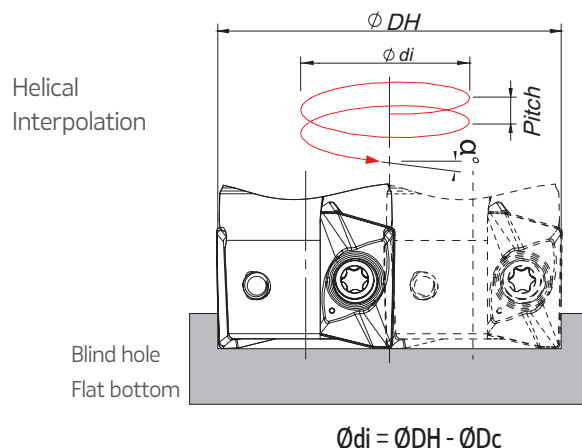
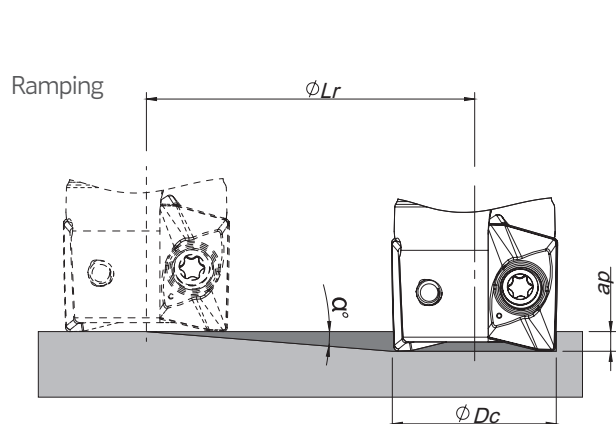

ϕDc	Ramping			Helical Interpolation		
				Diameter for Blind Hole, Flat Bottom Face (1)		Max Pitch/Rev.
	Max Ramp a°	Max a_p	Min Lr	ϕDH_{min}	ϕDH_{max}	
16	7,5	10,0	76,0	27,6	-	4,8
17	7,0	10,0	81,4	-	30,4	6,0
20	5,0	10,0	114,3	29,6	-	4,9
22	4,5	10,0	127,1	-	32,4	5,9
25	3,5	10,0	163,5	35,6	-	4,3
27	3,0	10,0	190,8	-	38,4	5,1
32	2,5	10,0	229,0	39,6	-	4,3
40	1,7	10,0	336,9	-	42,4	5,0
50	1,3	10,0	440,7	45,6	-	4,0
63	1,0	10,0	572,9	-	48,4	4,5
				49,6	-	3,7
				-	52,4	4,2
				59,6	-	3,8
				-	62,4	4,2
				75,6	-	3,3
				-	78,4	3,6
				95,6	-	3,2
				-	98,4	3,4
				121,6	-	3,2
				-	124,4	3,4

(1) using LP insert with radius 0,8 mm

Note: During helical interpolation do not exceed maximum pitch

When using HF insert or other different insert radius to calculate the ϕDH_{min} and ϕDH_{max} use the equation below:

- Minimum Diameter: $\phi DH_{min} = 2 \times (\phi Dc - (R \text{ corner radius} + F \text{ width of edge wiper}))$

- Maximum Diameter: $\phi DH_{max} = 2 \times (\phi Dc - R \text{ corner radius})$

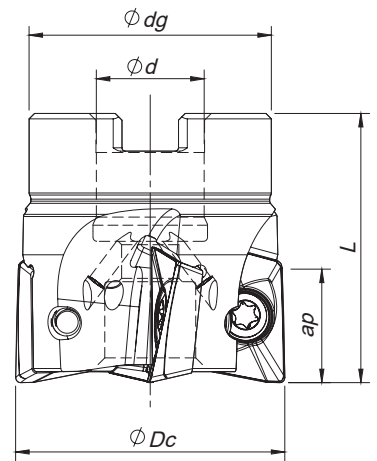
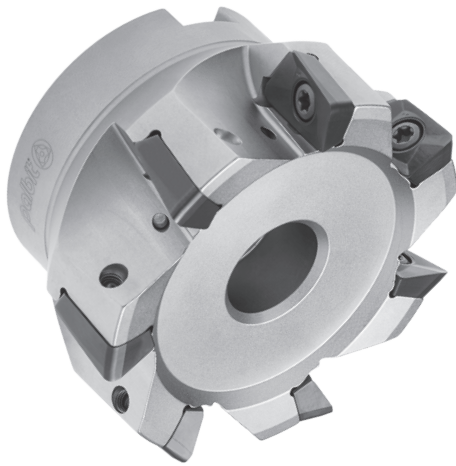

Arbor Mounting

$K_r=90^\circ$ | $\gamma_p=+7^\circ \sim +8^\circ$

Order code Código	Reference Referência Referencia		Dimensions Dimensões Dimensiones (mm)				Kg	Arbor Type	Ap max (mm)		Insert Pastilha Inserto	Stock	
			ϕDc	ϕd	ϕdg	L			LP MP LS LN	LN Z1/Z1W			
181090900	040A20290-04-07-016040		4	40	16	32	40	0,18	A	17,0	8,0	XPET 1706...	
181091000	050A20290-05-08-022040		5	50	22	42	40	0,29	A	17,0	8,0	XPET 1706...	
181196800	063A20290-06-08-022040		6	63	22	48	40	0,44	A	17,0	8,0	XPET 1706...	
181091200	080A20290-07-08-027050		7	80	27	60	50	0,92	A	17,0	8,0	XPET 1706...	
181091300	100A20290-08-08-032050		8	100	32	80	50	1,68	A	17,0	8,0	XPET 1706...	
181091400	125A20290-09-08-040063		9	125	40	90	63	3,01	A	17,0	8,0	XPET 1706...	

Stock item | Produto de stock | Itens de stock

Available under request | Disponível sobre consulta | Disponible bajo consulta

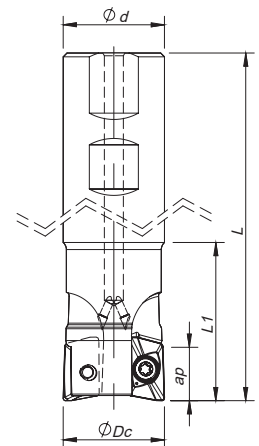

Weldon Shank

$K_r=90^\circ$ | $\gamma_p=+6^\circ \sim +7^\circ$

Order code Código	Reference Referência Referencia		Dimensions Dimensões Dimensiones (mm)				Kg	Ap max (mm)		Insert Pastilha Inserto	Stock	
			ϕDc	ϕd	ϕdg	L		LP MP LS LN	LN Z1/Z1W			
181090500	032W20290-02-06-032110		2	32	32	110	50	0,56	17,0	8,0	XPET 1706...	
181090600	032W20290-02-06-032200		2	32	32	200	60	1,10	17,0	8,0	XPET 1706...	
181090700	040W20290-03-07-032115		3	40	32	115	50	0,67	17,0	8,0	XPET 1706...	
181090800	040W20290-03-07-032200		3	40	32	200	60	1,19	17,0	8,0	XPET 1706...	

Stock item | Produto de stock | Itens de stock

Available under request | Disponível sobre consulta | Disponible bajo consulta

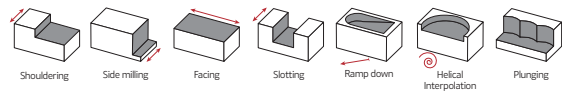

XPET 1706... Inserts | Pastilhas | Plaquetas

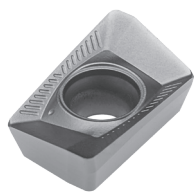

XPET-LP

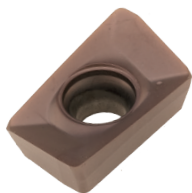

XPET-LS



XPET-MP



XPET-LN

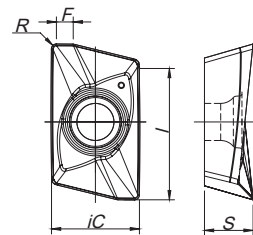

XPET-LP | LS | MP | LN

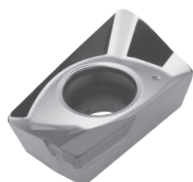

XPET-LN Z1

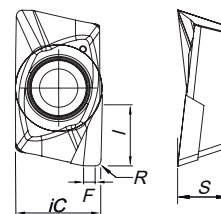

XPET-LN Z1

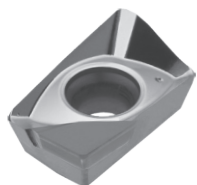

XPET-LN Z1W

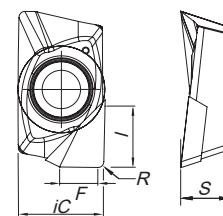

XPET-LN Z1W

Geometry code	ISO Reference	P		M		K		N		S		Dimensions Dimensões Dimensiones (mm)								
		CVD	PVD	PVD		CVD	PVD	UNC	PCD	PVD		iC	S	I	R	F				
		T9	T1	G6	X9	G6	L5	L9	T1	G6	10						D6	X9	G6	
1111986	XPET 170608 PDER-LP		⊗	⊗		⊗			⊗	⊗				⊗		11,30	6,35	17,50	0,80	1,80
1111987	XPET 170616 PDER-LP		⊗	⊗		⊗			⊗	⊗				⊗		11,30	6,35	17,50	1,60	1,20
1112223	XPET 170608 PDER-LS				⊗	⊗								⊗	⊗	11,30	6,35	17,50	0,80	1,80
1113373	XPET 170612 PDER-LS				○									○		11,30	6,35	17,50	1,20	1,56
1113361	XPET 170616 PDER-LS				⊗									⊗		11,30	6,35	17,50	1,60	1,19
1113362	XPET 170620 PDER-LS				⊗									⊗		11,30	6,35	17,50	2,00	2,10
1113363	XPET 170632 PDER-LS				⊗									⊗		11,30	6,35	17,50	3,20	0,96
1111988	XPET 170608 PDSR-MP	⊗	⊗	⊗			⊗	⊗	⊗							11,30	6,35	17,50	0,80	1,80
1111989	XPET 170616 PDSR-MP		⊗	⊗			⊗	⊗	⊗							11,30	6,35	17,50	1,60	1,00
1111990	XPET 170608 PDFR-LN											⊗				11,30	6,35	17,50	0,80	1,20
1111991	XPET 170620 PDFR-LN											⊗				11,30	6,35	17,50	2,00	1,00
1111992	XPET 170632 PDFR-LN											⊗				11,30	6,35	17,50	3,20	0,80
1113085	XPET 170608 PDFR-LN Z1													⊗		11,20	6,50	8,00	0,80	1,51
1113086	XPET 170608 PDFR-LN Z1W													⊗		11,20	6,50	8,00	0,80	4,91

⊗ First choice | Primeira opção | 1ª opción ⊗ Stock item | Produto de stock | Itens de stock ○ Available under request | Disponível sobre consulta | Disponible bajo consulta Insert order code = (1) Geometry Code + (2) Grade Code

SPARE PARTS Acessórios | Repuestos

Cutter ØDc	Insert Screw	Key (Torx)	Order separately		Retaining Screw
			Key (Torx - Nm)	Torque Value	
A20290 - 40-80	P0451001	XT20	DT2050	5	-
A20290 - 100	P0451001	PT20	DT2050	5	D1603500
A20290 - 125	P0451001	PT20	DT2050	5	D2004000
W20290 - 32-40	P0451001	XT20	DT2050	5	-

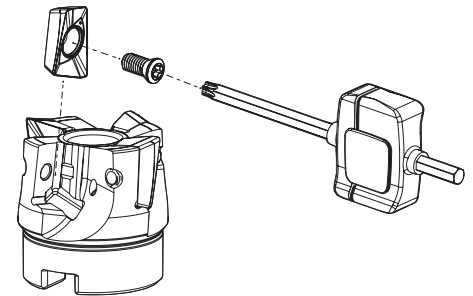

GRADES SELECTION GUIDE Guia para selecção de graus | Tabla para selección de calidades

ISO	PSM	Material	HB (Brinell)	Grades								PCD PDP410
				← Wear Resistance				Toughness →				
				PH0910	PH5705	PHP920	PHP930	PHH930	PH5740	PHS740	PH7740	
P	1	Unalloyed Steel	125-220			✓	✓			✓	✓	
	2	Low-Alloyed Steel	220-280			✓	✓			✓	✓	
	3	High-Alloyed Steel	280-380			✓	✓			✓	✓	
M	4	SS - Ferritic / Martensitic	200-330					✓				✓
	5	SS - Austenitic	200-330					✓				✓
	6	SS - Austenitic-ferritic (Duplex)	230-260					✓				✓
K	7	Malleable Cast Iron	130-230		✓	✓	✓			✓		✓
	8	Grey Cast Iron	180-245		✓	✓	✓			✓		✓
	9	Nodular Cast iron	160-250		✓	✓	✓			✓		✓
N	10	Aluminium and Non Ferrous	30-130	✓								✓
S	11	Heat Resistant Super Alloys	200-320					✓				✓

Good Conditions

●
 Average Conditions

⚙
 Difficult Conditions

CHIP-BREAKER SELECTION GUIDE Guia para aplicações do quebra- aparas | Guía para aplicación del rompevirutas

ISO	PSM	Material	HB (Brinell)	Chip-Breaker Application	
				1st choice	Difficult Operations
P	1	Unalloyed Steel	125-220	XPET 17... LP	XPET 17... MP
	2	Low-Alloyed Steel	220-280	XPET 17... LP	XPET 17... MP
	3	High-Alloyed Steel	280-380	XPET 17... MP	-
M	4	SS - Ferritic / Martensitic	200-330	XPET 17... LS	XPET 17... LP
	5	SS - Austenitic	200-330	XPET 17... LS	XPET 17... LP
	6	SS - Austenitic-ferritic (Duplex)	230-260	XPET 17... LS	XPET 17... LP
K	7	Malleable Cast Iron	130-230	XPET 17... LP	XPET 17... MP
	8	Grey Cast Iron	180-245	XPET 17... MP	-
	9	Nodular Cast iron	160-250	XPET 17... MP	-
N	10	Aluminium and Non Ferrous	30-130	XPET 17... LN LN Z1 LN Z1W	-
S	11	Heat Resistant Super Alloys	200-320	XPET 17... LS	XPET 17... LP

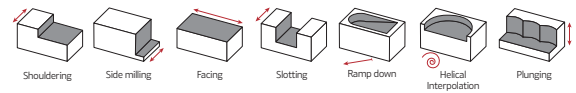

RECOMMENDED CUTTING CONDITIONS Condições de corte recomendadas | Condiciones de corte recomendables

ISO	PSM	Material	HB (Brinell)	Vc (m/min)								PCD
				← Wear Resistance						Toughness →		
				PH0910	PH5705	PHP920	PHP930	PHH930	PH5740	PHS740	PH7740	
P	1	Unalloyed Steel	125-220	-	-	180-250	160-230	-	-	140-220	140-200	-
	2	Low-Alloyed Steel	220-280	-	-	160-230	140-210	-	-	120-200	130-180	-
	3	High-Alloyed Steel	280-380	-	-	140-220	120-200	-	-	100-190	100-170	-
M	4	SS - Ferritic / Martensitic	200-330	-	-	-	-	140-210	-	-	130-180	-
	5	SS - Austenitic	200-330	-	-	-	-	120-170	-	-	110-160	-
	6	SS - Austenitic-ferritic (Duplex)	230-260	-	-	-	-	100-150	-	-	90-150	-
K	7	Malleable Cast Iron	130-230	-	160-290	160-270	-	-	160-260	-	140-220	-
	8	Grey Cast Iron	180-245	-	170-320	140-250	-	-	140-240	-	120-210	-
	9	Nodular Cast iron	160-250	-	140-200	120-210	-	-	120-200	-	100-190	-
N	10	Aluminium and Non Ferrous	30-130	100-2000	-	-	-	-	-	-	-	800-3000
S	11	Heat Resistant Super Alloys	200-320	-	-	-	-	30-110	-	-	30-100	-

ISO	PSM	Material	HB (Brinell)	Feed fz (mm/t)					
				XPET 17... LP	XPET 17... LS	XPET 17... MP	XPET 17... LN	XPET 17... LN Z1	XPET 17... LN Z1W
P	1	Unalloyed Steel	125-220	0,10-0,35	-	0,10-0,35	-	-	-
	2	Low-Alloyed Steel	220-280	0,10-0,35	-	0,10-0,35	-	-	-
	3	High-Alloyed Steel	280-380	0,10-0,30	-	0,10-0,30	-	-	-
M	4	SS - Ferritic / Martensitic	200-330	0,10-0,30	0,10-0,35	-	-	-	-
	5	SS - Austenitic	200-330	0,10-0,30	0,10-0,30	-	-	-	-
	6	SS - Austenitic-ferritic (Duplex)	230-260	0,10-0,25	0,10-0,25	-	-	-	-
K	7	Malleable Cast Iron	130-230	0,10-0,35	-	0,10-0,35	-	-	-
	8	Grey Cast Iron	180-245	0,10-0,35	-	0,10-0,35	-	-	-
	9	Nodular Cast iron	160-250	0,10-0,30	-	0,10-0,30	-	-	-
N	10	Aluminium and Non Ferrous	30-130	-	-	-	0,10-0,35	0,10-0,35	0,10-0,35
S	11	Heat Resistant Super Alloys	200-320	0,10-0,20	0,10-0,20	-	-	-	-

(Note 1) Cutting conditions $a_e/D_c=70\%$.

(Note 2)

Operation	a_e	Vc & fz	a_p (mm)
Slotting	100%	<20%	2,0-6,0
Shouldering	<50%	>8%	7,0-13,0
	≤25%	>12%	13,0-16,0

(Note 3) PH5... and PHS... can be used wet or dry. PH7... use only air.

(Note 4) It's possible to occur vibrations in certain cases. Please reduce depth of cut and / or reduce cutting conditions in following cases:

- When using long shank;
- When using long tool overhang with arbor type;
- When application has poor clamping rigidity or when using a low rigidity machine.

PLUNGING Mergulho | Plunge

$L \leq 3D_c$	$L > 3D_c$	S_{max}
f_z (mm/t)		
0,10-0,30	0,08-0,25	$S_{max} = \sqrt{D_c \cdot DR - DR^2}$

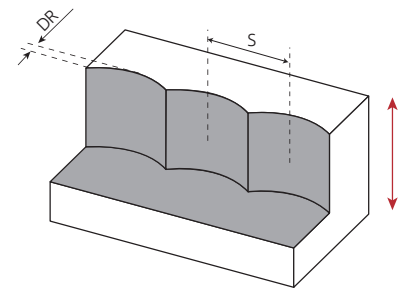

S max and DR corresponding cutting diameter Dc (mm)							
DR (mm)	Dc (mm)						
	32	40	50	63	80	100	125
1	5,6	6,2	7,0	7,9	8,9	9,9	11,1
2	7,7	8,7	9,8	11,0	12,5	14,0	15,7
3*	9,3	10,5	11,9	13,4	15,2	17,1	19,1
4*	10,6	12,0	13,6	15,4	17,4	19,6	22,0

* only for radius above 2,0mm

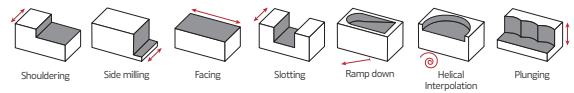

RAMPING AND HELICAL INTERPOLATION

Descida em rampa e interpolação helicoidal | Bajada en rampa e interpolación circular

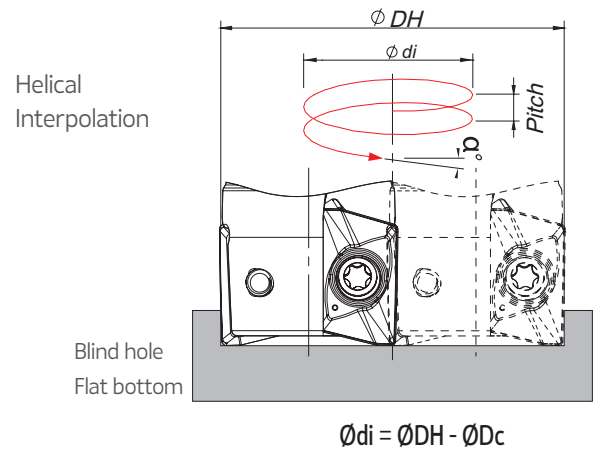
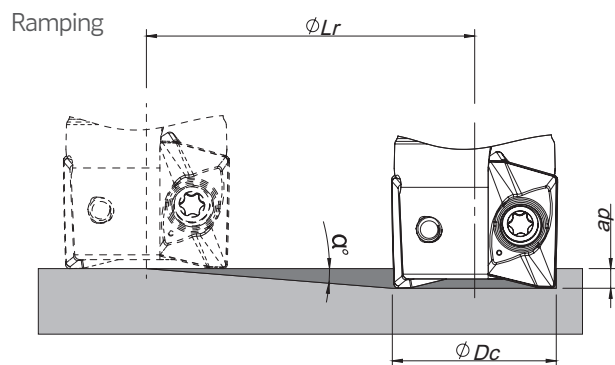

ϕDc	Ramping			Helical Interpolation		
				Diameter for Blind Hole, Flat Bottom Face (1)		Max Pitch/Rev.
	Max Ramp a°	Max a_p	Min Lr	ϕDH_{min}	ϕDH_{max}	
32	3,8	17,0	255,9	58,8 -	- 62,4	5,6 6,3
40	2,7	17,0	360,5	74,8 -	- 78,4	5,2 5,7
50	2,0	17,0	486,8	94,8 -	- 98,4	4,9 5,3
63	1,5	17,0	649,2	120,8 -	- 124,4	4,8 5,0
80	1,0	17,0	973,9	154,8 -	- 158,4	4,1 4,3
100	0,8	17,0	1217,5	194,8 -	- 198,4	4,2 4,3
125	0,7	17,0	1498,4	244,8 -	- 248,4	4,3 4,4

(1) using LP insert with radius 0,8 mm

Note: During helical interpolation do not exceed maximum pitch

When using HF insert or other different insert radius to calculate the ϕDH_{min} and ϕDH_{max} use the equation below:

- Minimum Diameter: $\phi DH_{min} = 2 \times (\phi Dc - (R \text{ corner radius} + F \text{ width of edge wiper}))$

- Maximum Diameter: $\phi DH_{max} = 2 \times (\phi Dc - R \text{ corner radius})$

LINEPRO 20090 | 20190 | 20290

XPET 06... - LN TEST REPORT

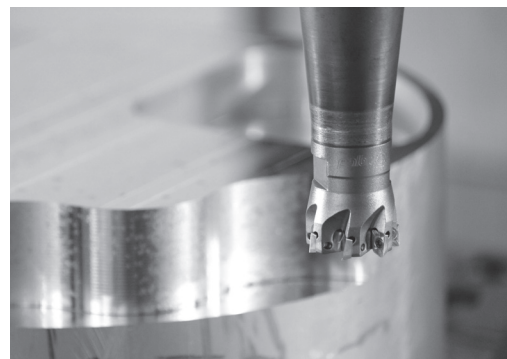
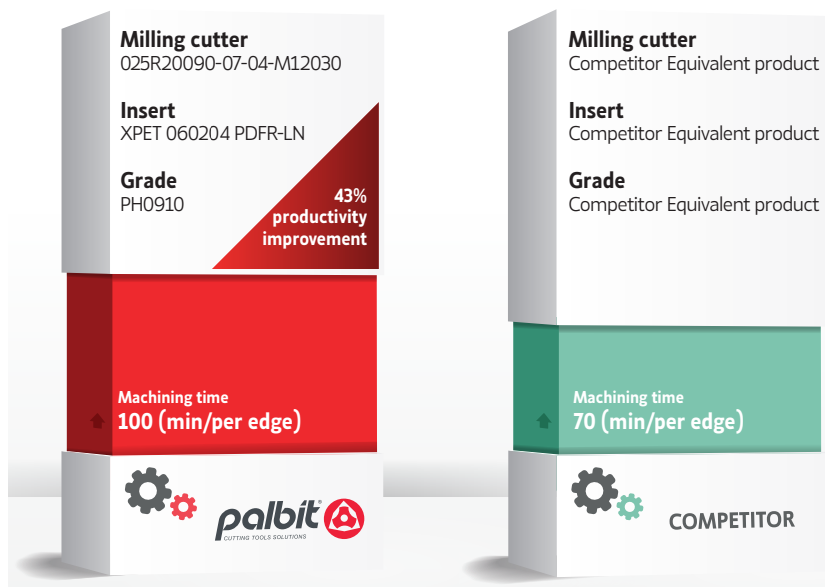

Work material: AISi10Mg	
Cutting speed: Vc (m/min)	650
Feed per tooth: fz (mm/t)	0,08
Depth of cut: ap (mm)	1,00
Width of cut: ae (mm)	15
Method of machining	Shoulder milling
Coolant	Air

XPHW 06... - MH TEST REPORT

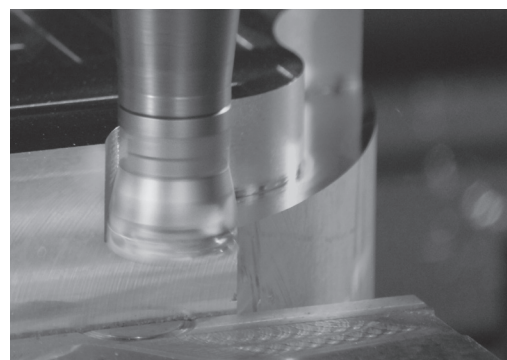
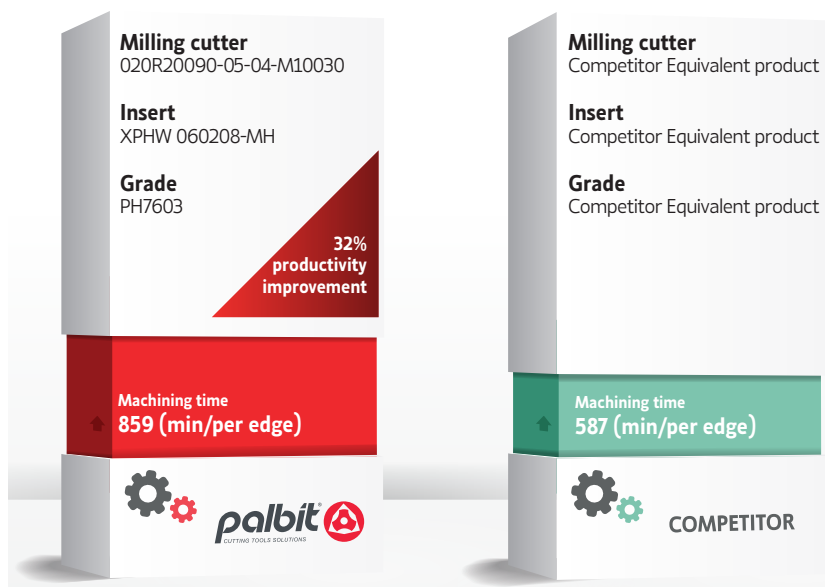

Work material: 40CrMnNiMo8 (1.2738) - (34-38 HRC)	
Cutting speed: Vc (m/min)	300
Feed per tooth: fz (mm/t)	0,10
Depth of cut: ap (mm)	0,18
Width of cut: ae (mm)	0,20
Method of machining	Shoulder milling
Coolant	Air

XPET 17... - MP PHS740 TEST REPORT

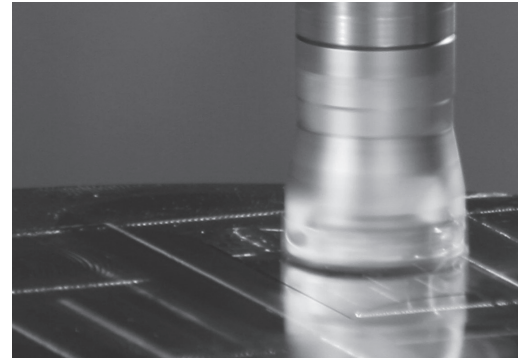

Work material: 1.0037 Structural Steel Unstable weld design and heavy interrupted cutting areas	
Cutting speed: Vc (m/min)	400
Feed per tooth: fz (mm/t)	0,20
Depth of cut: ap (mm)	2-3
Width of cut: ae (mm)	60
Method of machining	Sholder milling
Coolant	Yes

LINEPRO 20090 | 20190 | 20290

Square shoulder milling new generation



HEADQUARTERS

PALBIT. S.A.

P.O.Box 4 - Palhal

3854-908 - Branca ALB - Portugal

T (+351) 234 540 300 | F (+351) 234 540 301

palbit@palbit.pt | www.palbit.pt

Branch office:

PALBIT México, S de RL de CV

C/ Alfonso Esparza Oteo 37

Colonia Guadalupe Inn

Alcaldía Álvaro Obregón

01020 Ciudad de México

T (+52) 5555 454 543 | F (+52) 5552 509 190

info@palbit.com.mx | www.palbit.pt/mx

Branch office:

PALBIT Brasil

Av. João XXIII, nº20 Salas 41 e 65

Vila Gilda, Sto André, SP

CEP: 09190-500 – São Paulo

T (+55) 011 25 343 648

palbit@palbit.com.br | www.palbit.pt/br

